

Mixing and agitation

By

Dr. GHASSAN HASSAN ALDOORI

Mixing and agitation

Mixing and agitation is the heart of the chemical industry. Almost all process equipment's need some type of mixing or agitation. Uniformity of composition and desired flow pattern depends upon the type of agitator and the speed of agitation. It is also necessary to control the quality of the product, specifically where there is evaluation of heat and the temperature has to be maintained constant.

Agitation

- It is an induced motion of a material in a specified way.
- The pattern is normally circulatory.
- It is normally taken place inside a container.

Mixing

- Random distribution, into & through one another of two or more initially separate phases
- Liquids are agitated in a tank
- Bottom of the tank is rounded
- Impeller creates a flow pattern.
- Small scale tank (less than 10 litres) is constructed using Pyrex glass.
- For larger reactors/tank, stainless steel is used.
- Speed reduction devices are used to control the agitation speed.
- Mixing Flow : 3 patterns (axial, radial, tangential flow)

Purpose of Agitation:

1. Blending of two miscible liquids, such as ethyl alcohol and water.
2. Dissolving solids in liquids, such as salt in water.
3. Dispersing a gas in a liquid as fine bubbles,
4. Suspending of fine solid particles in a liquid,
- in the catalytic hydrogenation of a liquid, solid catalyst particles and hydrogen bubbles are dispersed in the liquid.
5. Agitation of the fluid to increase heat transfer between the fluid and a coil or jacket in the vessel wall.

Factors affecting the designing of the agitator:

Type of vessel , Circulation pattern, Location of the agitator , Shape and size of the vessel , Diameter and width of the agitator , Method of baffling , Power required and Shaft overhang .

Vortex

- If solid particles present within tank; it tends to throw the particles to the outside by centrifugal force.
- Power absorbed by liquid is limited.
- At high impeller speeds, the vortex may be so deep that it reaches the impeller

Preventing vortex

- a- Baffles on the tank walls
- b- Impeller in an angular off-center position

a- Baffles

Baffles are vertical plates that stick out radially from the tank wall

- If simple swirling motion is required no baffling is necessary.
- Generally 4 baffles are used located 90° apart.
- Baffle width is 10-12% tower diameter
- Baffle height 2 times impeller height

With coils in the tank, baffles are placed inside the coil.

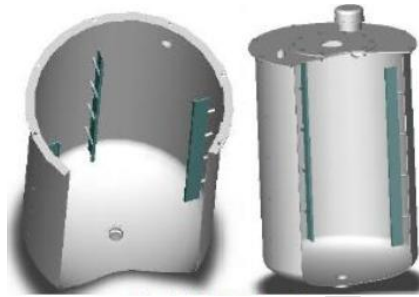
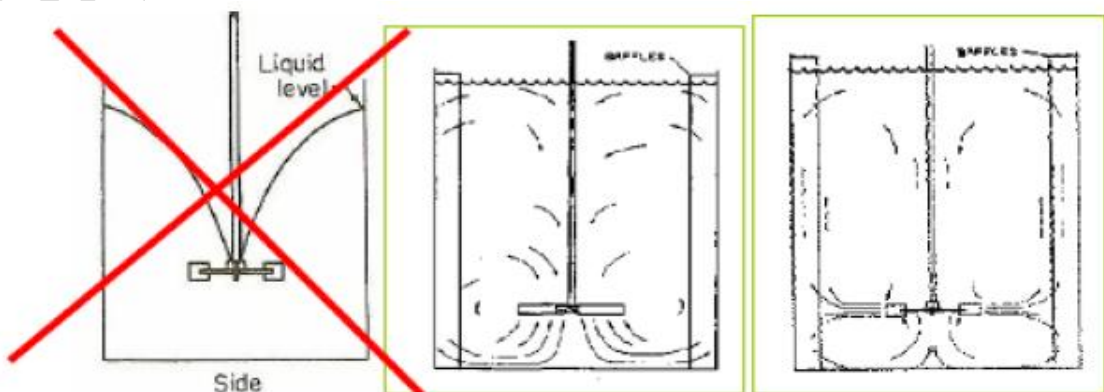
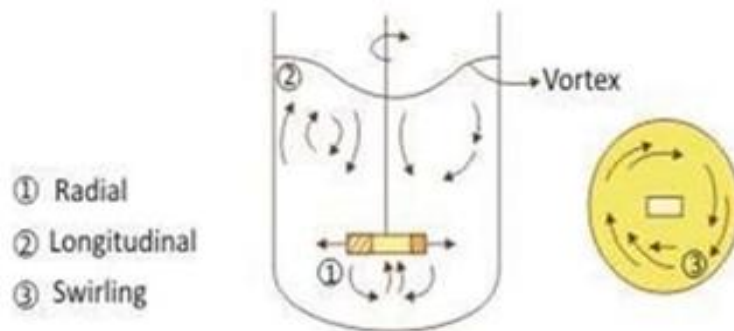

Figure : Baffled vessel.

Flow patterns in agitated vessels:

There are three principle currents in the vessel during agitation (a) radial (perpendicular to the shaft) (b) tangential to the circular path) (c) longitudinal (parallel to the shaft)



a- Vortex

b- Axial flow turbine

c-Radial flow turbine

Agitator

- The equipment consists of a tank with an insulated jacket , baffles , shaft with motor , impeller.
- Other accessories such as thermometer and dip – leg are inserted inside the tank.

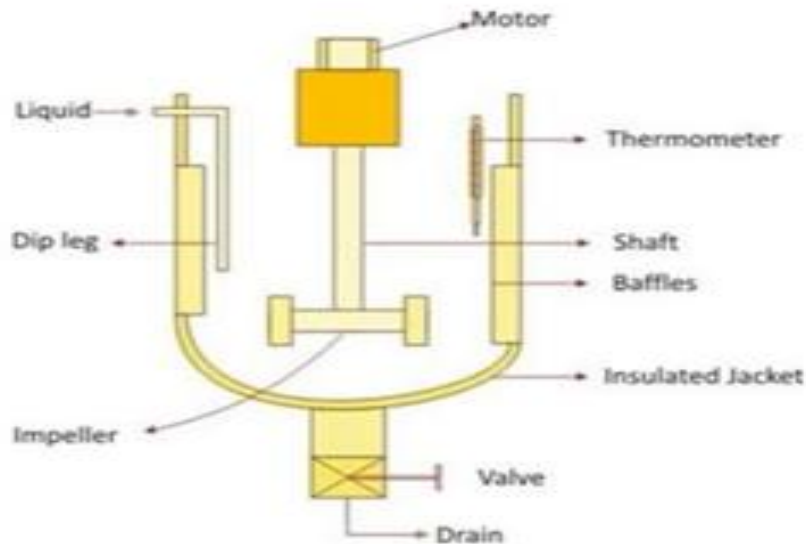

Agitation of liquids:

-The unit operation is used to prepare liquid – mixture by bringing in contact two liquids in a mechanically agitated vessel or container.

-Agitation refers to the induced motion of liquid in some defined way, usually in circulatory pattern and is achieved by some mechanical device.

Why agitation?

- Dispenses a liquid which is immiscible with the other liquid by forming an emulsion or suspension of few drops.
- suspends relatively lighter solid particles.
- Promotes heat transfer between the liquid in the tank and jacket surrounding the container.
- Blends miscible liquids.

Tank with impeller and baffle

- The role of baffles is to remove stratification in the radial direction and improve mixing
- Baffles 4 , Impeller 1

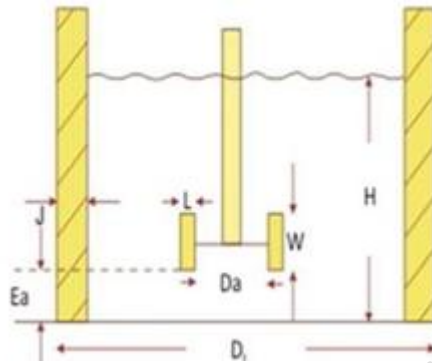

$$\frac{Da}{Dt} = \frac{1}{3}, \frac{H}{Dt} = 1, \frac{J}{Dt} = \frac{1}{12}, \frac{Ea}{Da} = 1, \frac{W}{Da} = \frac{1}{5}, \frac{L}{Da} = \frac{1}{4}$$

Two types of geometrical configuration

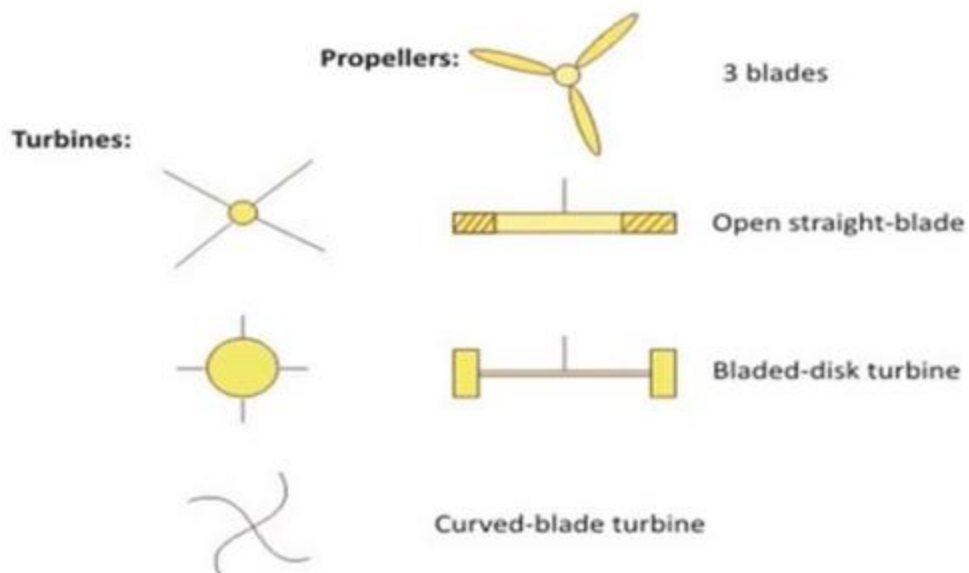

DESIGN OF AGITATION / MIXING TANK

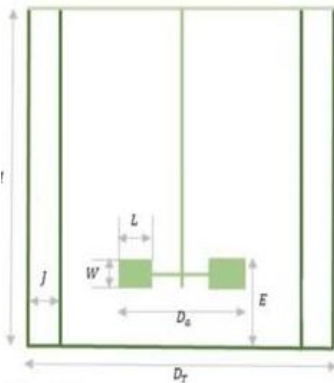

Ideal Size:

$$H = D_T \quad W = \frac{1}{5} D_a$$

$$D_a = E = \frac{1}{3} D_T \quad L = \frac{1}{4} D_a$$

$$J = \frac{1}{12} D_T$$

DESIGN CONSIDERATIONS:

Impeller Reynold's Number

$$N_{Re} = \frac{\rho N D_a^2}{\mu}$$

N = rotational speed, rps

$N_{Re} \geq 20,000$	Turbulent
$20,000 > N_{Re} > 10$	Transition
$N_{Re} \leq 10$	Laminar

Mixing Power

$$P = N_p \rho D_a^5 N^3$$

N_p = Power Number

= Obtained from graph of N_{Re} vs Impeller type

Mixing time, t_m (or t_b)

$$t_m N \left(\frac{D_a}{D_T} \right)^2 = 5 (N_{Fr})^{\frac{1}{6}} \left(\frac{H}{D_T} \right)^{0.5}$$

$$t_m = \frac{45 (N_{Fr})^{\frac{1}{6}}}{N} \text{ (Ideal Size)}$$

N_{Fr} = Froude Number

$$N_{Fr} = \frac{N^2 D_a}{g}$$

Tip Speed, v

$$v = \pi D_a N$$

(usually ≥ 4 m/s)

Equipment Scaling

with Power: $P = k D_a^5 N^3$

with Tip Speed: $v = \pi N D_a$

with Mixing time: $t_m = \frac{k N_{Re}}{N}$

Other Dimensionless Groups:

Pumping Number: $N_Q = \frac{Q}{N D_a^3}$

Q = total volumetric flowrate discharged by an impeller

Dimensionless Blend Time: $N_b = t_b N$

Example 1:

An agitated tank with a standard Rushton impeller is required to disperse gas in a solution of properties similar to those of water. The tank will be 3 m diameter (1 m diameter impeller). A power level of 0.8 kW/m³ is chosen. Assuming fully turbulent conditions and that the presence of the gas does not significantly affect the relation between the Power and Reynolds numbers ($N_p = 0.7$)

- (a) What power will be required by the impeller?
- (b) At what speed should the impeller be driven?
- (c) If a small pilot scale tank 0.3 m diameter is to be constructed to test the process, at what speed should the impeller be driven?

(a)

$$P = 0.8 \frac{kW}{m^3} \times V$$

$$V = \frac{\pi}{4} D_T^2 H$$

Assuming $D_T = H = 3m$

$$V = \frac{\pi}{4} (3)^3 = 21.2 m^3$$

$$P = 17 kW$$

(b)

$$P = N_p \rho D_a^5 N^3$$

$$N_p = 0.7$$

$$\rho = 1000 \frac{kg}{m^3}$$

$$D_a = 1m$$

$$17 \times 10^3 = 0.7 (1000) (1)^5 N^3$$

$$N = 2.90 Hz = 173 \frac{rev}{min}$$

Equipment Scaling

with Power: $P = k D_a^5 N^3$

(c) for large tank:

$$P = k D_a^5 N^3$$

$$17 \times 10^3 = k (1)^5 (2.90)^3$$

$$k = 697$$

for small tank:

Assuming $D_T = H = 0.3 m$

$$P = 0.8 \frac{kW}{m^3} \left(\frac{\pi}{4} \right) (0.3)^2 (0.3) = 17W$$

Assuming $D_a = \frac{1}{3} D_T = \frac{1}{3} (0.3) = 0.1m$

$$17 = 697 (0.1)^5 N^3$$

$$N = 13.5 Hz = 807 \frac{rev}{min}$$

Example 2:

For producing an oil-water emulsion, two portable three-bladed propeller mixers are available; a 0.5 m diameter impeller rotating at 1 Hz and a 0.35 m impeller rotating at 2 Hz. Assuming turbulent conditions prevail, which unit will have the lower power consumption?

for 0.5 m diameter:

$$P_{0.5} = kD_a^5 N^3$$

$$P_{0.5} = k(1)^3(0.5)^5 = 0.03125k$$

for 0.35 m diameter:

$$P_{0.35} = kD_a^5 N^3$$

$$P_{0.35} = k(2)^3(0.35)^5 = 0.0420k$$

$$\frac{P_{0.5}}{P_{0.35}} = 0.744$$

Thus the 0.5 m diameter impeller will have the lower power consumption; 74.4 % of the 0.35 m diameter impeller.

Types of impeller:

Paddle, Anchor, Propeller, Turbine, Beater, Gate Type, Helical, Ribbon. Toothed, Marine and Plate Type.

Paddle type agitator :

- Speed range 5-300rpm
- Used for large size vessels
- Agitator size almost touching vessel wall
- Normally used for reaction vessel having jacket by providing good heat transfer area
- Doesn't allow solid buildup at the wall

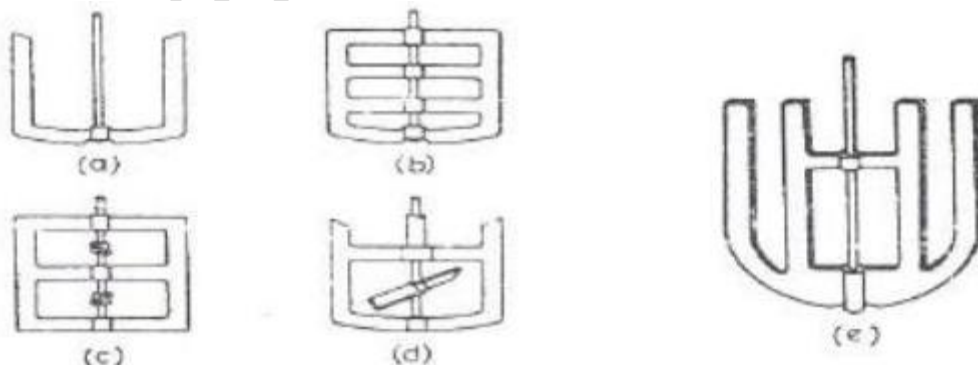

Paddle Agitators :(a)Anchor, (b)Gate, (c) Gate with pitched cross arms,(d) Anchor with pitched cross arms ,(e) combined anchor and gate.

Propeller type agitator

- Axial flow impellers
- Maximum flow is achieved at axis of agitator
- Maximum vessel size is 1m³

- Maximum speed is 415 rpm
- Diameter of propeller is 15-30% of vessel diameter



Fig :Propeller type agitator

Terminology in power calculation

a) flow number $q \propto nD_a^3$ $N_Q = \frac{q}{nD_a^3}$

- Where q is the volumetric flow rate , measured at the tip of the blades , n is the rotational speed (rpm), Da is the impeller diameter
- Total flow was shown to be

$$q_T = 0.92nD_a^3 \left(\frac{D_t}{D_a} \right)$$

- N_Q is constant for each type of impeller . For flat-blade turbine(FBT), in a baffled vessel, N_Q may be taken as 1.3; For marine propellers (Square pitch), $N_Q = 0.5$; For four blade 45° turbine , $N_Q = 0.87$
- For HE impeller- $N_Q = 0.47$

The Reynolds number, NRe

$$N_{RE} = \frac{D_a^2 n \rho}{\mu}$$

The Froude number , NFr

$$N_{Fr} = \frac{n^2 D_a}{g}$$

Froude No. is a measure of the ratio of the inertial stress to the gravitational per unit area acting on the fluid .It appears in the dynamic situations where there is significant wave motion on a liquid surface .Important in ship design . Unimportant when baffles are not used or $Re < 300$.

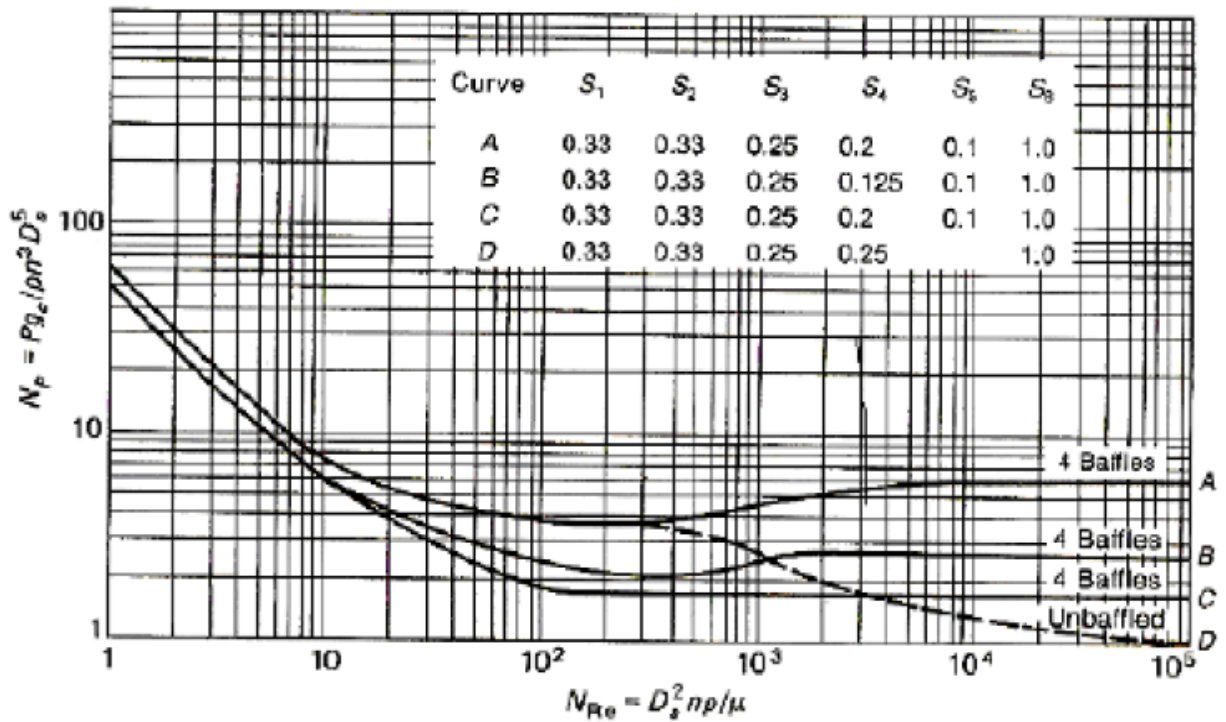

Power number N_p versus N_{Re} for six-blade turbines. With the dashed portion of curve D, the value of N_p read from the figure must be multiplied by N_{Re}^m .

Fig: Power curve for turbine type agitator

Curve A = Vertical blades, $W/Da = 0.2$

Curve B = Vertical blades, $W/Da = 0.125$

Curve C = pitched blade

Curve D = unbaffled tank

The power number is calculated as:

$$\phi = N_p = \frac{P}{\rho N^3 D_a^5} \quad \text{and} \quad N_{Re} = \frac{\rho N D_a^2}{\mu}$$

Where NP = power number

P = power requirement, kg.m

g_c = gravitational acceleration , m/sec²

ρ = density of the fluid ,kg/m³

μ = viscosity of the fluid ,kg/m.sed

Da = diameter of the vessel

For unbaffled vessel:

$$\phi = N_p = \frac{P g_c}{\rho N^3 D_a^5} \quad \text{for } N_{Re} \leq 300$$

$$\phi = N_p = \frac{\alpha - \log_{10} N_{Re}}{N_{Fr} \beta} \quad \text{For } N_{Re} > 300$$

$$N_{Fr} = \frac{N^2 D_a}{g} \quad \text{Fraud Number}$$

Here the values of α and β are given as the function of diameter of the agitator:

Diameter Da	Da/D	α	β
10	0.3	1.0	4.0
15	0.33	1.0	4.0

If the configuration changes the graph will be changed and also the values.

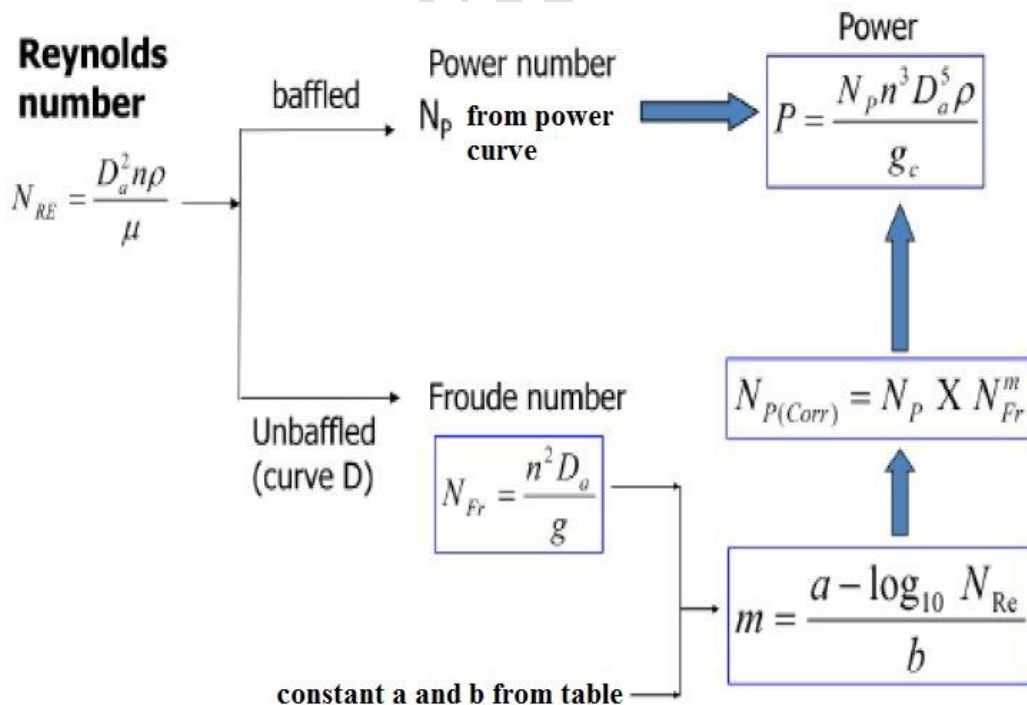

Power number curves for various type of impeller:

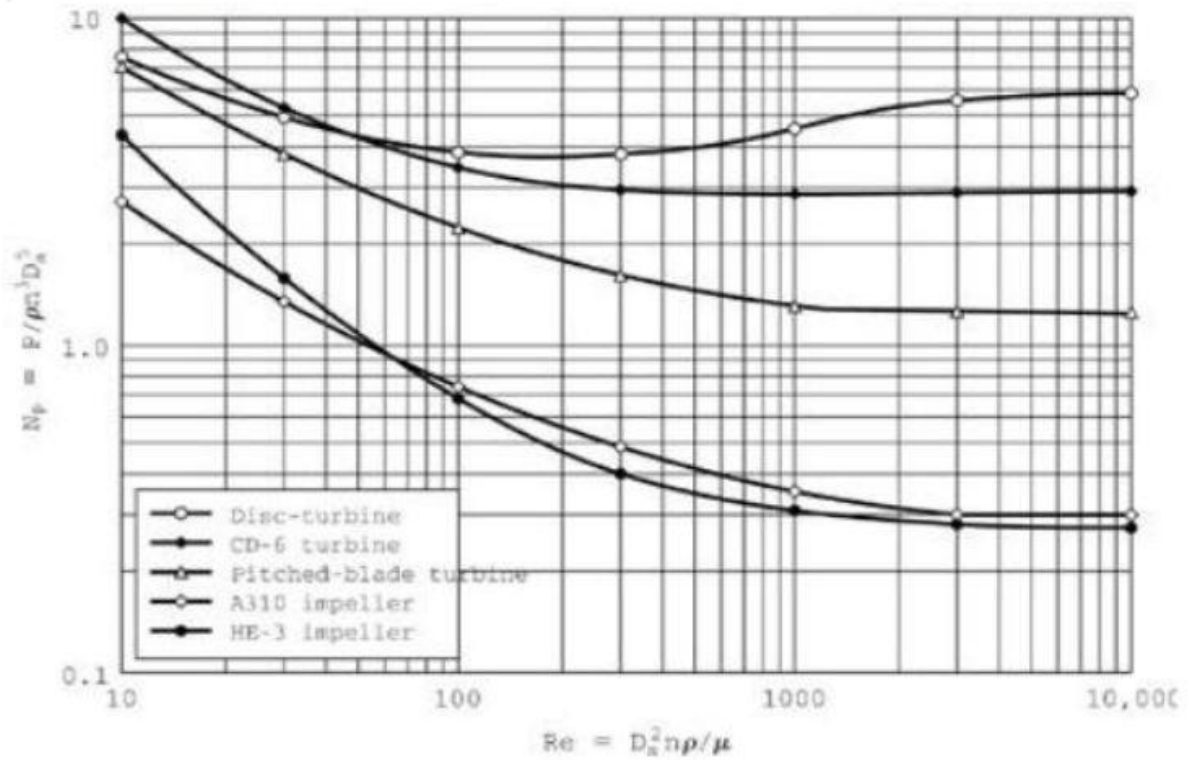

Power N_p vs . Reynolds number Re for turbines and impellers.

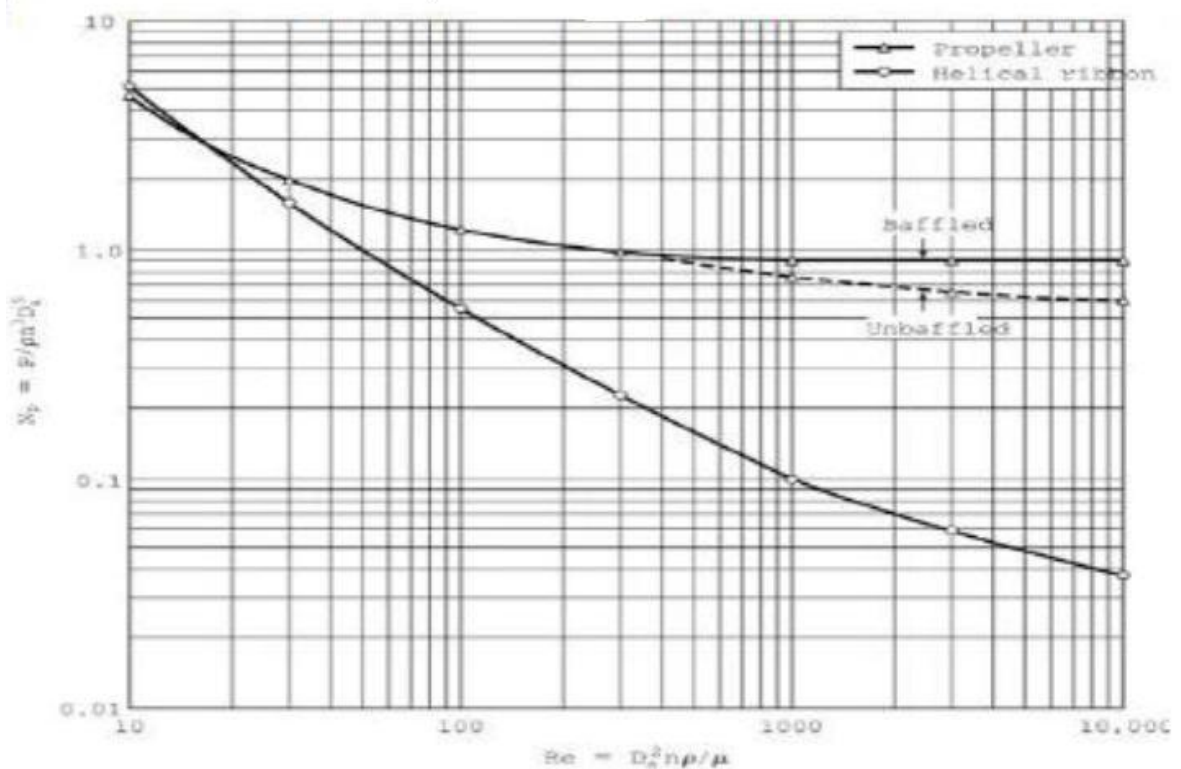

Power N_p vs . Reynolds number Re for marine propellers and helical ribbons.

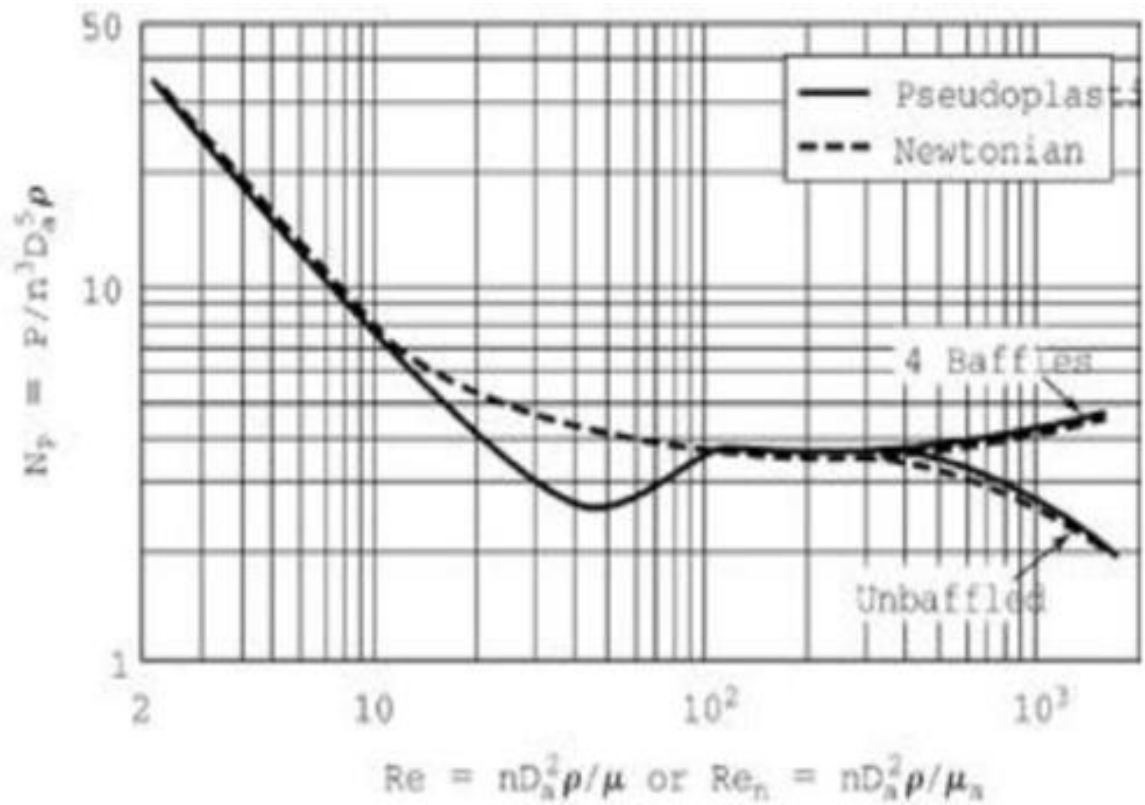

Power correlation for a 6 – blade turbine in pseudo plastic liquids

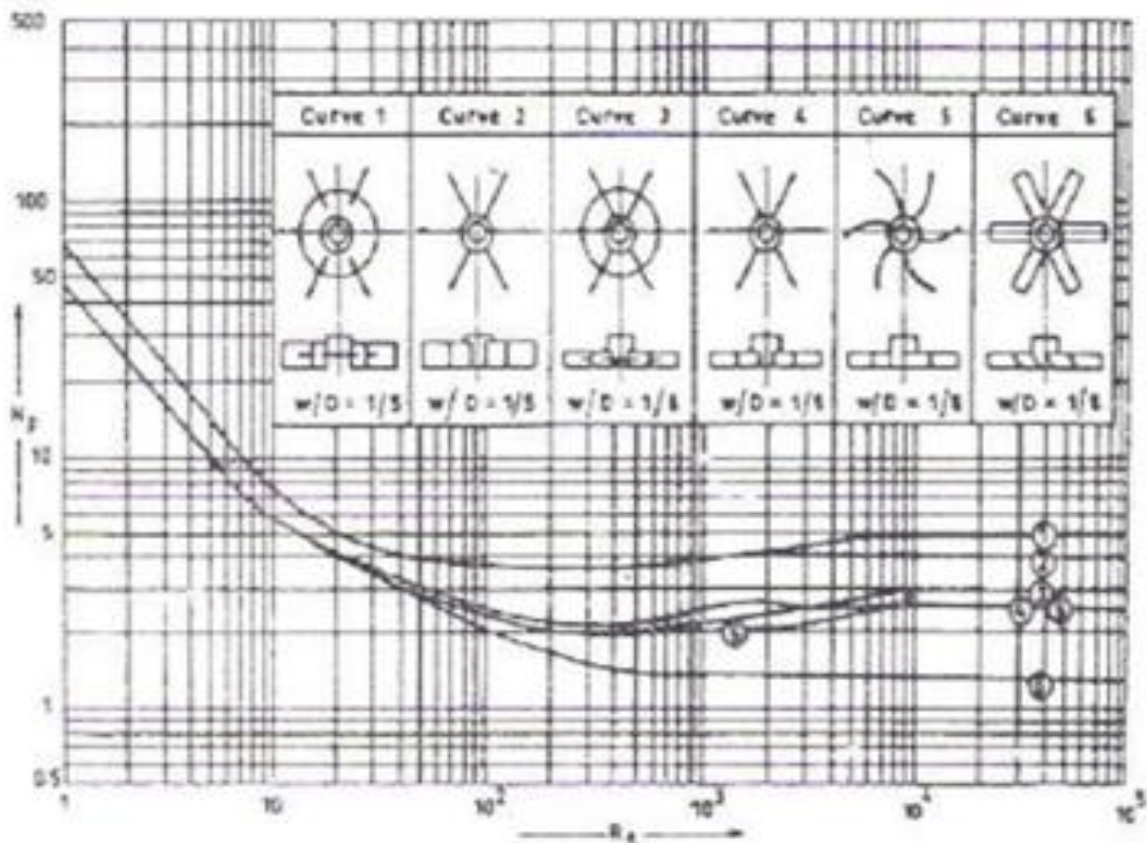

For turbine type agitator with 6 flat blades liquid height equal to vessel height and 4 baffles are installed (power correlations for baffled turbine impellers).

Power Consumption:

- Power requirement $P = \frac{N_p n^3 D_a^5 \rho}{\xi_c}$

- At low $N_{Re} (< 10)$, density is no longer a factor $N_p = \frac{K_L}{N_{Re}}$

$$P = \frac{K_L n^2 D_a^3 \mu}{\xi_c}$$

- At $N_{Re} > 10^4$ in baffled tanks, P is independent of N_{Re} and viscosity is not a factor

$$N_p = K_T \quad P = \frac{K_T n^3 D_a^5 \rho}{\xi_c}$$

- K_L and K_T are constants for various types of impellers and tanks

Type of Impeller	K_L	K_T
Propeller, 3 blades	41	0.32
Pitch 1.0	55	0.87
Pitch 1.5		
Turbine	65	5.75
6-blade disk ($S_3=0.25$ $S_4=0.2$)	70	4.80
6 curved blades ($S_4=0.2$)	-	1.63
6 pitched blades (45° , $S_4=0.2$)	44.5	1.27
4 pitched blades (45° , $S_4=0.2$)		
Flat paddle, 2 blades (45° , $S_4=0.2$)	36.5	1.70
Anchor	300	0.35

Example3:

A flat-blade turbine with six blades is installed centrally in a vertical tank. The tank is 1.83 m in diameter, the turbine is 0.61 m in diameter & is positioned 0.61 m from the bottom of the tank. The turbine blades are 127mm wide. The tank is filled to a depth of 1.83m with a solution of 50% caustic soda at 65.6°C, which has a viscosity of 12cP and a density of 1498 kg/m³. The turbine is operated at 90 rpm. What power will be required to operate the mixer if the tank was baffled?

Solution :

For baffled:

$$N = 90 \text{ rpm} / 60 \text{ sec} = 1.5 \text{ r/sec}$$

$$D_a = 0.61 \text{ m}$$

$$\mu = 12 \text{ cp} = 12 \times 10^{-3} \text{ kg/m.sec}$$

$$N_{RE} = \frac{D_a^2 n \rho}{\mu} = \frac{(0.61)^2 (1.5)(1498)}{12 \times 10^{-3}} = 69600$$

for $Re > 10000$, $N_p = K_T = 5.8$ from curve A for baffle ($N_{Re} = 69600$),
 $N_p = 5.8$ (or from table given before)

$$P = \frac{N_p n^3 D_a^5 \rho}{g_c}$$

$$P = (5.8)(1.5)^3 (0.61)^5 (1498) = 2476.6 \text{ mN/sec} = 2476.6 \text{ W}$$

For unbaffle:

From fig, curve D ($N_{Re} = 69600$), $N_p = 1.07$

Froud number,

$$N_{Fr} = \frac{n^2 D_a}{g} = \frac{(1.5)^2 (0.61)}{9.81} = 0.14$$

$$m = \frac{a - \log_{10} N_{Re}}{b} = \frac{1.0 - \log_{10} 69600}{40} = -0.096$$

$$N_{p(\text{Corrected})} = N_p \times N_{Fr}^m = 1.07 \times 0.14^{-0.096} = 1.29$$

Thus power,

$$P = \frac{N_p n^3 D_a^5 \rho}{g_c} = (1.29)(1.5)^3 (0.61)^5 (1498) \\ = 550 \text{ mN} / \text{s} = 550 \text{ W}$$

Example 4:

Calculate the theoretical power for a six-blade flat blade turbine agitator with diameter $D_A = 3$ m running at a speed of $N = 0.2$ rev/s in a tank system conforming to the standard tank configuration. The liquid in the tank has a dynamic viscosity $\mu = 1$ Pa.sec and a density of $\rho = 1000$ kg/m³.

Solution:

$$Re_M = \frac{\rho N D_A^2}{\mu}$$

Substituting the given values

$$Re_M = \frac{(1000 \text{ kg/m}^3)(0.2 \text{ rev/s})(9.0 \text{ m}^2)}{1.0 \text{ Pa s}}$$

$$Re_M = 1800$$

From the graph of ϕ against Re_M in figure . $\phi = P_o = 4.5$

The theoretical power for mixing is

$$\begin{aligned} P_A &= P_o \rho N^3 D_A^5 \\ &= (4.5) (1000 \text{ kg/m}^3) (0.008 \text{ rev}^3/\text{sec}^3)(243 \text{ m}^5) \\ &= 8748 \end{aligned}$$

Example 5:

Calculate the theoretical power for a six – blade flat blade turbine agitator $D_A = 0.1$ running at $N = 16$ rev/s in a tank system without baffles but otherwise conforming to the standard tank configuration illustrated in figure the liquid in the tank has a dynamic viscosity of $\mu = 0.08$ Pa.s and a density of $\rho = 900$ kg/m³ . for this configuration $\alpha = 1$ and $\beta = 40$?

Solution:

The Reynolds number for mixing is given by

$$Re_M = \frac{\rho N D_A^2}{\mu}$$

$$= \frac{(900 \text{ kg/m}^3)(16 \text{ rev/s})(0.01 \text{ m}^2)}{0.08 \text{ Pa s}}$$

$$= 1800$$

$$P_A = \phi \rho N^3 D_A^5 \left(\frac{N^2 D_A}{g} \right)^y$$

Now

$$y = \frac{\alpha - \log Re_M}{\beta}$$

With $\alpha = 1$ and $\beta = 40$ and $\log 1800 = 3.2553$

Therefore

$$y = \frac{-2.2553}{40} = -0.05638$$

Substituting known values $N^2 D_A = (256 \text{ rev}^2/\text{s}^2)(0.1 \text{ m})$

$$\text{Substituting known values} \quad \frac{N^2 D_A}{g} = \frac{(256 \text{ rev}^2/\text{s}^2)(0.1 \text{ m})}{9.81 \text{ m/s}^2}$$

$$= 2.610$$

$$\text{So} \quad \left(\frac{N^2 D_A}{g} \right)^y = 2.610^{(-0.05638)} = 0.9479$$

Therefore

$$P_A = (2.2)(900 \text{ kg/m}^3)(4096 \text{ rev}^3/\text{s}^3)(0.00001 \text{ m}^5)(0.9479)$$

$$= 76.88 \text{ W}$$